

40 - 60W WELL GLASS INDUSTRIAL HIGH BAY LIGHT

Energy efficient wellglass is designed for various industrial application with excellent thermal management offering durability and superior performance thereby reducing operational cost.



FEATURES

- ✦ Housing made of High Pressure die cast aluminium
- ✦ Ingress protection of IP66
- ✦ Luminaire efficacy of 110 Lumens/W & 130 Lumens/W
- ✦ UV protected clear PC cover with option of diffused cover
- ✦ Potted Driver & High Power LED
- ✦ Total Harmonic Distortion <10 %
- ✦ Internal surge protection of 4KV
- ✦ 50000 burning hours
- ✦ Operating Temperature: -10 degree-50 degree

TECHNICAL SPECIFICATIONS

WATTAGE	VOLTAGE	LUMINAIRE EFFICACY	CCT (K)	PF	CRI
40 ~ 60	240	>110 Lm / W	5700	0.95	>70

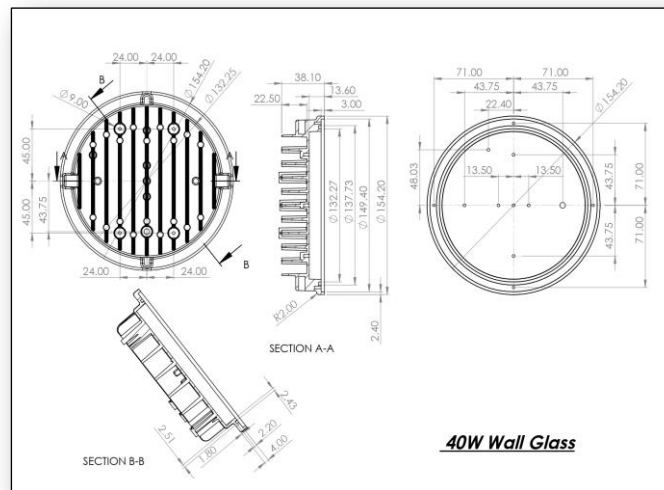

BENEFITS

- ✦ **Unique finless design aiding in lesser dust accumulation**
- ✦ **Vertical fins for 360 degree heat dissipation**
- ✦ **Uniform light distribution with high grade PC Cover**
- ✦ **Sleeve provided in Eye bolt for protection against vibration**

APPLICATIONS

It is used in various industries like Cement Industry , Power Industry , Food & beverage Industry Distillery Industry and material Handling Industry.